

DAVIS®

Always Ahead™

Raised Floor Trunking System



BS IEC CE KEMA

www.davis.com.my



Davis, well known for introducing modern underfloor cable management system 60 years ago, is a pioneer in cable management systems. Today, Davis remains at the forefront of the cable management industry.

With more than half a century of cable management leadership and technology, Davis continues to innovate and improvise its vast range of cable management products which complies with the most stringent technical specifications and the highest standards of today's modern office requirements.

Davis has of a team of dynamic and dedicated pool of design engineers and professional sales force, providing first class service and support for the company's wide range of products. Our people will always be there to ensure all its high-performance products meet the ever changing trends and demands of smart homes, stylish office designs, intelligent building structures and sophisticated monumental skyscrapers.









At Davis, we always produce what the market wants. We always keep up with new challenges of the electrical industry. Davis adopts a policy of continuous improvement, producing competitively priced products and is committed to give excellent customer service which keeps us *"Always Ahead"*.

With strategically located manufacturing and support facilities and an extensive distribution network across the region, Davis is well positioned to meet every exact need and requirement of our customers all over the world.

DAVIS range of products includes:-

- Modular Flushfloor Trunking System
- Raised Floor Trunking System
- Underfloor Trunking System
- Heavy Duty Underfloor Trunking System
- 63A 240/415V Raised Floor Bustrack System
- 200A – 6300A Busway System



	INTRODUCTION	1
	RAISED FLOOR SERVICE BOXES	2-4
	RAISED FLOOR LAYOUT VIEW	5-6
	RAISED FLOOR TRUNKING	7
	TECHNICAL DATA	7-8
	LAYOUT DESIGN	9
	CABLE CAPACITY GUIDE	9
	INSTALLATION GUIDE	10
	ACCESSORIES	11-12

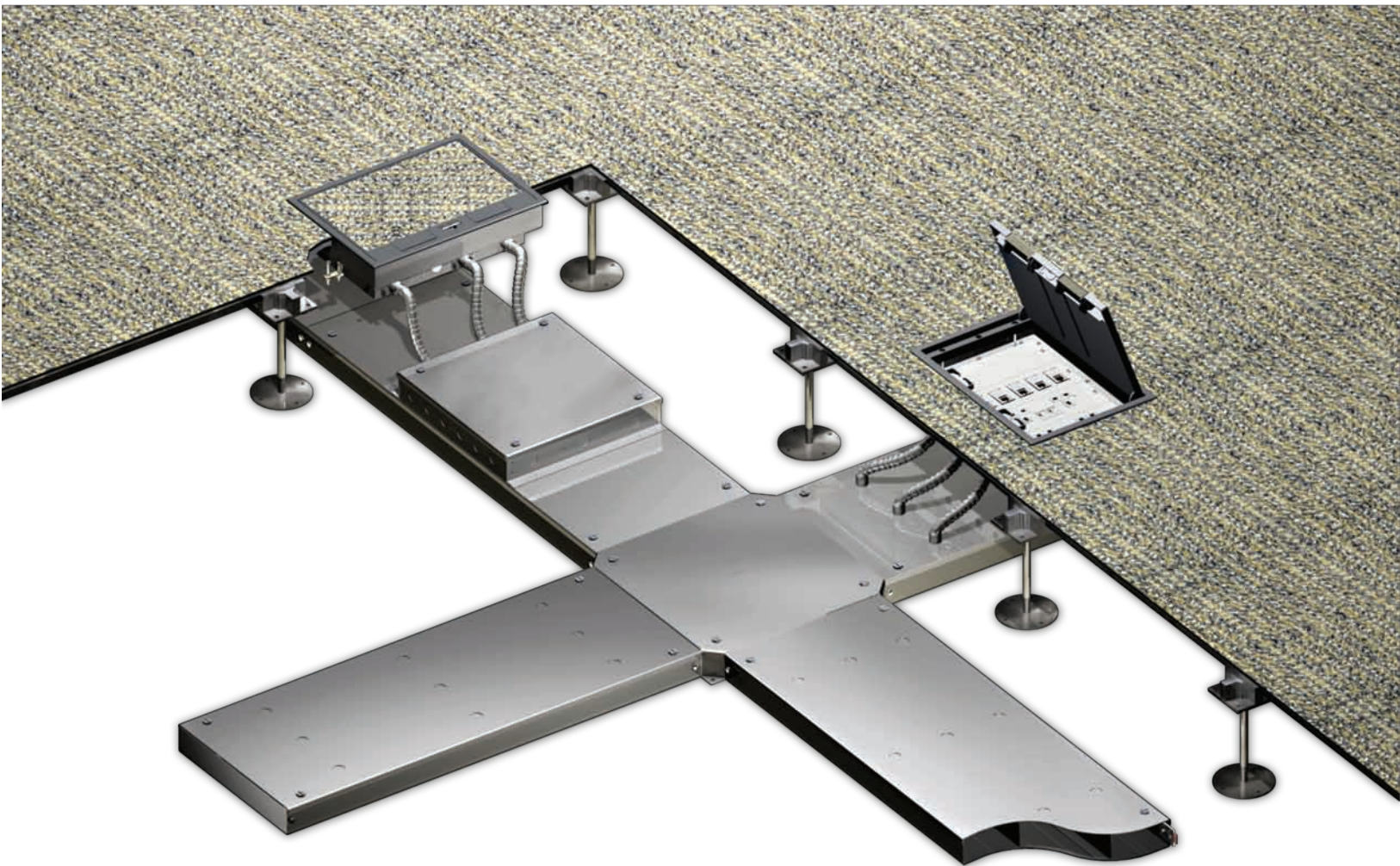

INTRODUCTION

DAVIS Raised Floor Trunking System has been specially designed for the distribution of power, voice and data services in raised floor installations. This highly adaptable system provides the solution to virtually every challenge met by developers, architects and those involved in providing an efficient and easily managed system for both new constructions and buildings which are in the process of being refurbished and modernized.

DAVIS Raised Floor Trunking System consists of:

- A Raised Floor Trunking, complete with DAVIS Quick Fix Lid system to ensure ease of installation and maintenance.
- A 2 or 3 compartment Service Outlet box that accepts a wide range of power, voice and data socket plates.
- A comprehensive range of Junction Boxes including 'tee', 'elbow' and 'cross' type.
- A comprehensive range of accessories including Header Boxes, End Caps, Reducers and Offset Units.

FEATURE BENEFITS

- Constructed from pre-galvanized steel sheets in accordance with BS 4678 : Part 2, BS EN 50085-2-2 & IEC 61084-2-2.
- Designed and manufactured to meet the MOB PS2 PS/SPN specification for raised floors.
- The system incorporates numerous design features to ensure a fast and simple installation.
- Flexibility and versatility with regard to future modifications & expansions.
- Designed to support CAT 6 structured cabling systems.
- Floorboxes are IP30 rated in accordance with BS EN 60529.
- Service outlet box depths of 45, 80 and 85mm are available to cater for different floor voids.
- Choice of 2, 3 or 4 compartment floorboxes.
- Wide range of power and data accessories available to meet all requirements.



CP270 SERVICE BOX

Handle

- stainless steel handle to improve accessibility and durability.

Flap Handle

- retractable when not in use and to stop the ingress of dust.

Grommet with Cable Retainer

- enable the trap to be shut flat while cable protruding safely through the grommet.

Levelling System

- to adapt to final floor level by a maximum upward lift of 16mm.

DAVIS® Quick-Lock Mechanism

- an accessible quick-lock mechanism to ease installation and reduce installation time.
- patent no.: MY-137215-A

CP270 Trap and Frame

- 6mm recess.
- made of flame retardant, high impact Nylon 66 plastic.
- trap is prevented from detachment by a unique hinge mechanism.
- trap opens up to more than 90° and is self-closing.
- trap is 180° rotatable.
- colour comes in light grey.
- trap is reinforced with a pre-galvanized infill plate for maximum strength and durability.

Flanged Frame

- flanged edge to prevent carpet from fraying out.

Outlet Panels

- a wide range of power and data accessories plates.
- cater up to 3 accessories plates to meet high density wiring requirements.

Basic Box

- comes with 20mm/25mm knockout holes to accept conduits entering from either side of the box.
- 80mm box depth providing 35mm plug clearance and 35mm wiring space.
- overall box dimension 290mm(W) x 247mm(D) x 80mm(H).
- recommended raised floor mounting hole to be cut 278mm x 235mm.
- other heights are also available.

Compartment Segregation

- supplied with 2 dividers.
- convertible from 3 to 2 compartments and vice versa.

SPECIFICATIONS

Basic Box:

Pre-galvanized steel sheet to BS EN 10142, BS EN 50085-1 or JIS G3302.



QUANTEC
SERVICE
BOX

Quantec Trap and Frame

- 6mm recess.
- made of flame retardant, high impact ABS plastic.
- trap is prevented from detachment by a unique hinge mechanism.
- trap opens up to maximum 80° and is self-closing.
- colour comes in light grey.
- trap is reinforced with a pre-galvanized steel sheet infill plate for maximum strength and durability.

Handle

- stainless steel handle to improve accessibility and durability.

Grommet with Cable Retainer

- enable the trap to be shut flat while cable protruding safely through the grommet.

Flanged Frame

- flanged edge to prevent carpet from fraying out.

Flap Handle

- retractable when not in use and to stop the ingress of dust. Comes with sponge.

Levelling System

- to adapt to final floor level by a maximum upward lift of 16mm.

Outlet Panels

- a wide range of power and data accessories plates.
- cater up to 4 accessories plates to meet high density wiring requirements.

Basic Box

- comes with 20mm/25mm knockout holes to accept conduits entering from either side of the box.
- 85mm box depth providing 37mm plug clearance and 37mm wiring space.
- overall box dimension : 339mm(W) x 244mm(D) x 85mm(H).
- recommended raised floor mounting hole to be cut 327mm x 232mm.
- other heights are also available.

Compartment Segregation

- supplied with 3 dividers.
- convertible from 3 to 2 or 4 compartments and vice versa.

DAVIS® Quick-Lock Mechanism

- an accessible quick-lock mechanism to ease installation and reduce installation time.
- patent no.: MY-137215-A

SPECIFICATIONS

Basic Box:

Pre-galvanized steel sheets to BS EN 10142 ,
BS EN 10327 or JIS G3302.

RAISED FLOOR SERVICE BOX

RFCP270



* The trap and frame are moulded from fire retardant engineering plastic (Nylon 66) reinforced with pre-galvanized steel sheets infill plate.

Box Size L X W (mm)	No. of Compartments	Model
270X230X80	2	RFCP270/2
270X230X80	3	RFCP270/3

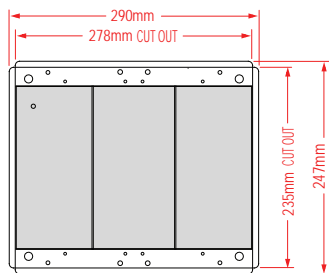

TOP VIEW

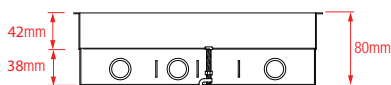

FRONT VIEW

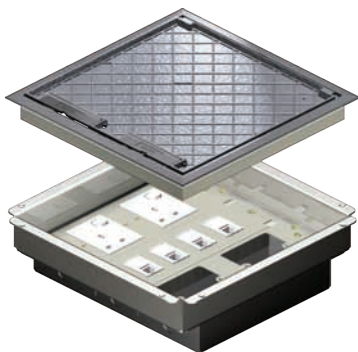

* The trap is made of high pressure die-cast alloy. The flange, flap handles, cable retainers and hinges are moulded from fire retardant engineering plastic (Nylon 66) to give greater mechanical strength.

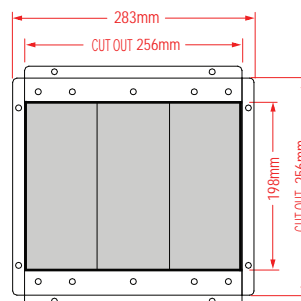

TOP VIEW

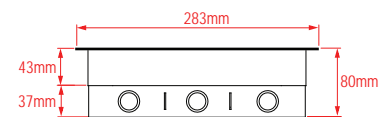

FRONT VIEW

QUANTEC

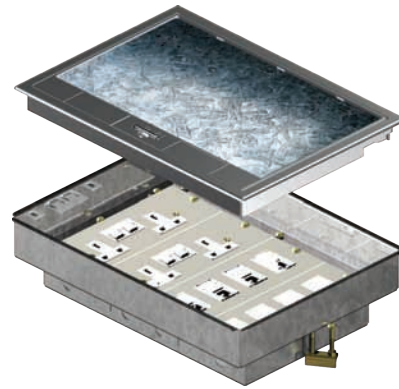

* The trap and frame are moulded from high impact fire retardant ABS plastic reinforced with pre-galvanized steel sheets infill plate.

Box Size L X W X H (mm)	No. of Compartments	Model
339X244X85	3	QRF3
339X244X85	4	QRF4

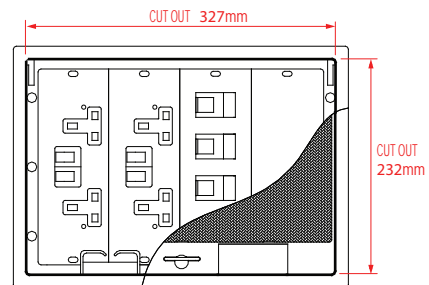

TOP VIEW



FRONT VIEW

RFCP470

Box Size L X W (mm)	No. of Compartments	Model
250X250	2	RFCP470/2
250X250	3	RFCP470/3

MAXIMUM FLEXIBILITY

- provide flexibility and versatility with regard to future modifications & expansions.
- a service outlet box that can be mounted at virtually any location and direction on the raised floor.

SERVICE OUTLET BOX

- adapts to a universal range of panel-mounted accessories for power, data and voice services.

HEADER BOX

- used to connect trunking to service outlet box.
- allows the cable to protrude out of the trunking with a wider bending radius.

JUNCTION BOX

- is complemented with a two-piece metal flyover in compliance with electromagnetic interferences (I.E.E regulations) and to assist with the pulling of cables at the crossover.
- universal flyover for 'through', 'tee', 'elbow' and 'cross' configurations.
- support CAT 6 compliance.

END CAP

- to terminate trunking run and prevent the ingress of dust and dirt.

TRUNKING SYSTEM

- constructed from pre-galvanized steel sheets in accordance with BS 4678 : Part 2, BS EN 50085-2-2 & IEC 61084-2-2.

SPEEDY INSTALLATION

- complete with DAVIS Quick Fix Lid system to ensure ease of the installation and maintenance.

ACCESSIBILITY

- comes with 20mm / 25mm knockout holes for conduit entry.

TRUNKING CONNECTOR

- a pair of internal connector plates to secure two adjacent trunkings.
- a piece of copper earth link is provided for each trunking joint to ensure earthing continuity.



TECHNICAL SPECIFICATIONS

Raised Floor Trunking

Material	Pre-galvanized steel sheets in accordance with BS EN 10142, BS EN 10327 or JIS G3302.
International Standards	The trunking supplied shall comply with BS 4678 : Part 2, BS EN 50085-2-2 & IEC 61084-2-2.
Construction	DAVIS Raised Floor Trunking system has been specially designed for the distribution of power, voice and data services in raised floor installation. This highly adaptable system provides the solution to virtually every challenge met by developers, architects and those involved in providing an efficient and easily managed system for both new constructions and buildings which are in the process of being refurbished and modernized.
Earthing	A copper earth link shall be used for each joint to maintain electrical earth continuity and shall be installed at the internal side of the trunking.
Corrosion	Any screws or bolts/nuts used in any part of the trunking, particularly for joint of each trunking and the earth link shall be corrosion resistant (electroplated to BS EN ISO 2081), smooth and should not cause any damage to wiring during installation.
DAVIS Quick Lid	A raised floor trunking incorporates the DAVIS Quick Fix Lid system to ensure ease of the installation and maintenance.
Standard Thickness	1.0mm
Standard Lengths	2.3 or 2.44 meters
No. of Compartments	2, 3 and 4 compartments
Standard heights	40mm and 50mm

Raised Floor Service Outlet Box / Junction Box

Material	The cover for the service outlet box shall be constructed from engineering plastic (nylon 66) or high impact fire retardant ABS plastic, reinforced with pre-galvanized steel sheets infill plate.
Strength	Service outlet box shall be able to withstand the following load tests:- <ol style="list-style-type: none"> Concentrated load test – 3.0kN @25mm sq. steel platen. Concentrated load test – 4.5kN @300mm sq. steel platen. Uniform distributed load test – 8.0kN/m². Maximum deflection shall not exceed 3mm for these loadings (BS EN 50085-2-2).
No. of Compartments	2, 3 and 4 convertible compartments
DAVIS Quick Lock Mechanism	a patented Quick Lock Mechanism (patent no.: MY-137215-A) to ease installation and reduce installation time.
Electromagnetic Compatibility	Junction box shall be provided with the pre-galvanized steel sheets flyover for compartment segregation. Due to electromagnetic interferences, the use of plastics flyover is not suitable. This is to comply with the latest I.E.E. regulations. A Service outlet box shall have fully segregated outlet panels to isolate the services in compliance with the latest I.E.E regulations.



LAYOUT DESIGN

A COMB DESIGN

More suitable for low density service area. This pattern uses less trunking and offers an extremely cost-effective solution. This design is typically used for modular flushfloor, raised floor and underfloor systems.

A FISHBONE DESIGN

Widely used in areas where tenants require a good degree of flexibility in reorganizing work areas. This design is typically used for modular flushfloor, raised floor and underfloor systems.

A GRID DESIGN

Most widely used pattern where the tenants require a greater degree of flexibility in reorganizing work areas. This pattern allows the work place capacity to be increased and the capacity of rewiring through individual ring networks. This design is typically used for modular flushfloor and underfloor systems.

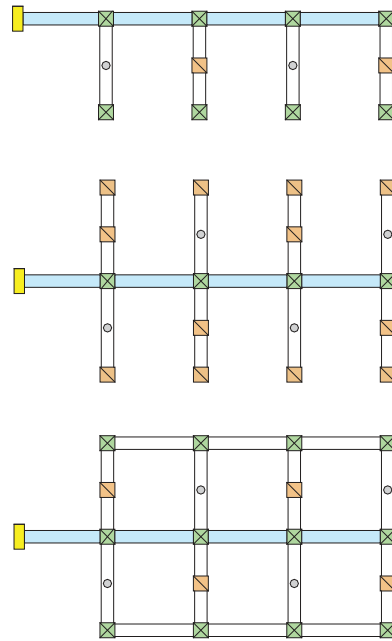

- Service Outlet Box
- Vertical Access Box
- Universal Junction Box
- Header Runs
- Pedestal Box



CABLE CAPACITY GUIDE

			250x40x2C	250x40x3C	300x40x2C	300x40x3C	450x40x2C	450x40x3C	250x50x2C	250x50x3C	300x50x2C	300x50x3C	450x50x2C	450x50x3C
Capacity (mm ²) per compartment (45% fill)			2103	1391	2531	1676	3813	2531	2657	1757	3197	2117	4817	3197
Cable type	CSA (mm ²)	Cable Factor	Capacity (no.) per compartment (45% fill)											
Power Cables														
PVC Stranded	1.5 mm ²	8.6	244	161	294	194	443	294	308	204	371	246	560	371
	2.5 mm ²	12.6	166	110	200	133	302	200	210	139	253	168	382	253
	4 mm ²	16.6	126	83	152	100	229	152	160	105	192	127	290	192
	6 mm ²	21.2	99	65	119	79	179	119	125	82	150	99	227	150
	10 mm ²	35.3	59	39	71	47	108	71	75	49	90	59	136	90
	16 mm ²	47.8	44	29	52	35	79	52	55	36	66	44	100	66
Twin & Earth	2.5 mm ²	86	24	16	29	19	44	29	30	20	37	24	56	37
	4 mm ²	99	21	14	25	16	38	25	26	17	32	21	48	32
	6 mm ²	148	14	9	17	11	25	17	17	11	21	14	32	21
Data Cables														
CAT 5e UTP	5.5 dia	30.2	69	46	83	55	126	83	87	58	105	70	159	105
CAT 5e STP	6 dia	36	58	38	70	46	105	70	73	48	88	58	133	88
CAT 6 UTP	6.5 dia	42.2	49	32	59	39	90	59	62	41	75	50	114	75
CAT 6 STP	7 dia	49	42	28	51	34	77	51	54	35	65	43	98	65

The table above gives the available capacity units on 45% factor (IEE Wiring Regulation), applied to internal wiring area and serves as a guideline only.

OUTLET PANELS

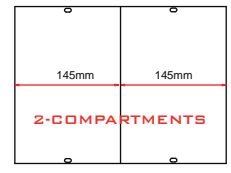
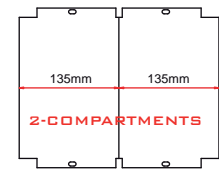
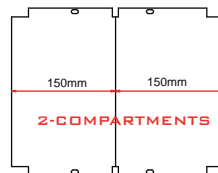
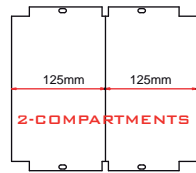
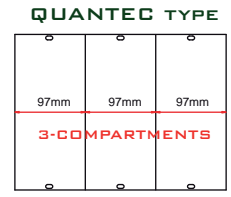
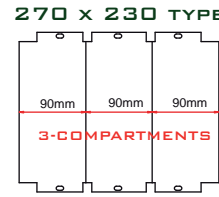
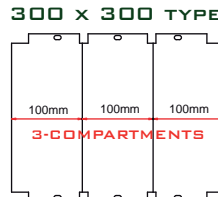
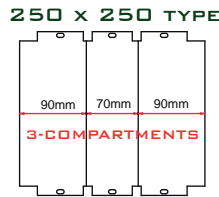
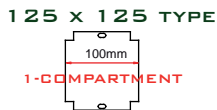
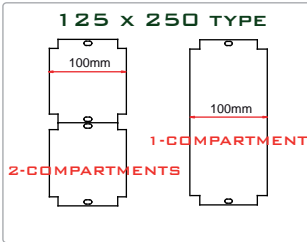
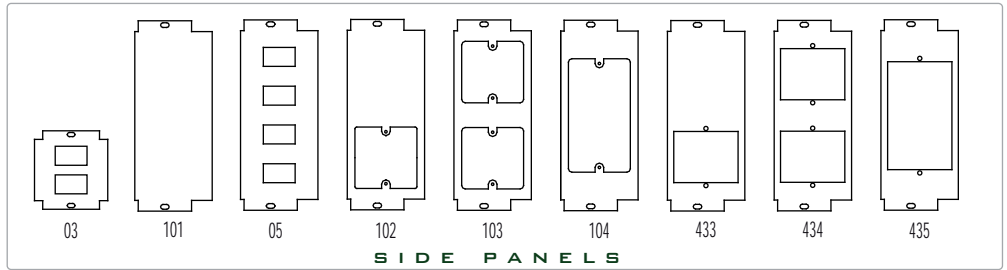
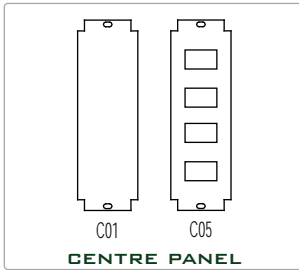

Description	125 x 125		125 x 250		250 x 250			QUANTEC		
	1-Comp.	1-Comp.	2-Comp.	2-Comp.	3-Comp.		2-Comp.	3-Comp.	4-Comp.	
					CENTRE	SIDES				
Blank plate				OP125 101	OP70 C01	OP90 101	ST145 C01	ST97 C01	SF72 C01	
2 nos. Cut-out RJ45 37x22.5mm	OP125 03S		OP125 03D							
4 nos. Cut-out RJ45 37x22.5mm		OP100 05D		OP125 05	OP70 C05	OP90 05	SF145 C05	ST97 C05	SF72 C05	
Cut-out in accordance to BS4662 1G	OP125 102S	OP100 102D	OP125 102D	OP125 102		OP90 102	SF145 102	ST97 102		
Cut-out in accordance to BS4662 2x1G		OP100 103D		OP125 103		OP90 103	SF145 103	ST97 103		
Cut-out in accordance to BS4662 2G		OP100 104D		OP125 104		OP90 104	SF145 104	ST97 104		
1G 13A DAVIS Switched Socket Outlet	OP125 433S	OP100 433D	OP125 433D	OP125 433		OP90 433	SF145 433	ST97 433		
2x1G 13A DAVIS Switched Socket Outlet		OP100 434D		OP125 434		OP90 434	SF145 434	ST97 434		
2G 13A DAVIS Switched Socket Outlet		OP100 435D		OP125 435		OP90 435	SF145 435	ST97 435		

Description	300 x 300			270 x 230		
	2-Comp.	3-Comp.		2-Comp.	3-Comp.	
		CENTRE	SIDES		CENTRE	SIDES
Blank plate	OP150 101	OP100 C01	OP100 101	OP135 2 101	OP90 2 C01	OP90 2 101
4 nos. Cut-out RJ45 37x22.5mm	OP150 05	OP100 C05	OP100 05	OP135 2 05	OP90 2 C05	OP90 2 05
Cut-out in accordance to BS4662 1G	OP150 102	OP100 C102	OP100 102	OP135 2 102	OP90 2 C102	OP90 2 102
Cut-out in accordance to BS4662 2x1G	OP150 103	OP100 C103	OP100 103	OP135 2 103	OP90 2 C103	OP90 2 103
Cut-out in accordance to BS4662 2G	OP150 104	OP100 C104	OP100 104	OP135 2 104	OP90 2 C104	OP90 2 104
1G 13A DAVIS Switched Socket Outlet	OP150 433	OP100 C433	OP100 433	OP135 2 433	OP90 2 C433	OP90 2 433
2x1G 13A DAVIS Switched Socket Outlet	OP150 434	OP100 C434	OP100 434	OP135 2 434	OP90 2 C434	OP90 2 434
2G 13A DAVIS Switched Socket Outlet	OP150 435	OP100 C435	OP100 435	OP135 2 435	OP90 2 C435	OP90 2 435

Note : All outlet panels supplied are epoxy coated. Non-standard outlet panels are also available upon request.

13A SWITCHED SOCKET OUTLETS - SIDE WIRE ENTRY

DAVIS one and two gang 13A Switched Socket Outlets are specially designed to be slim (24mm) with side wire entries to suit underfloor service boxes.

Rating / Standard : 240V, 13A a.c / BS 1363 : Part 2

3 terminals to : 4x2.5mm² cables each or 3x4.0mm² cables each accommodate

Approved by : JKR & Suruhanjaya Tenaga

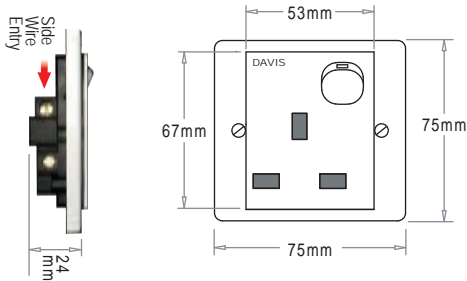

Model	Description
D13/1GS	1 Gang 13A Switched Socket
D13/1GSN	1 Gang 13A Switched Socket with Neon
D13/1GS RD	1 Gang 13A Switched Socket with Red Dolly
D13/1GSN RD	1 Gang 13A Switched Socket with Neon and Red Dolly

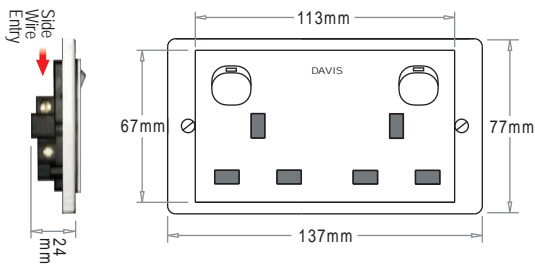

Model	Description
D13/2GS	2 Gang 13A Switched Socket
D13/2GSN	2 Gang 13A Switched Socket with Neon
D13/2GS RD	2 Gang 13A Switched Socket with Red Dolly
D13/2GSN RD	2 Gang 13A Switched Socket with Neon and Red Dolly

UNDERFLOOR BOX EXTENSION SCREW TERMINALS

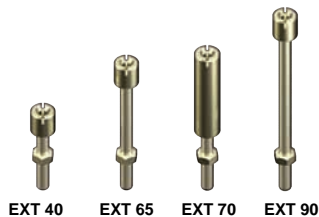

Model	Description
EXT 70 + EXT 65	120 - 160mm
EXT 90	95 - 120mm
EXT 65	75 - 95mm
EXT 40	STANDARD (50 - 72mm)

DATA & TELEPHONE OUTLETS

DAVIS modular type RJ45 & RJ11 data outlets are specially designed to suit underfloor service boxes.

Comply with : TIA/EIA-568-B specifications

Come with : IDC connector and shutter

Hole cut-out : 37mm x 22.5mm

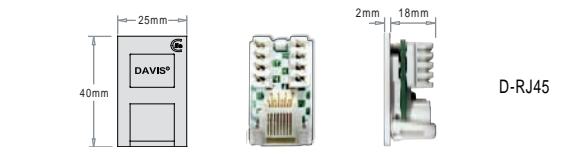
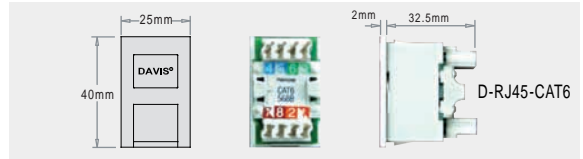

Model	Description
D-RJ11	4-Way RJ11 Telephone Socket Outlet
D-RJ45	CAT 5e RJ45 Data Outlet - TIA/EIA-568-B
D-RJ45-CAT6	CAT 6 RJ45 Data Outlet - TIA/EIA-568-B

SERVICE ACCESS GROMMETS

DAVIS Service Access Grommet provides a convenient and low-cost solution to data, power and voice services for raised access floors. Recommended cut-out hole is $\phi 127$ mm.

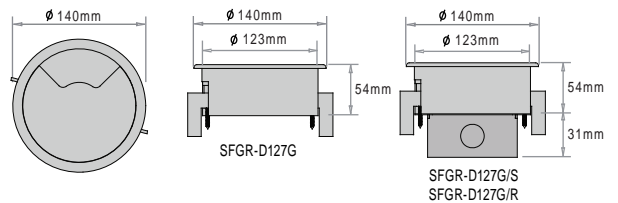

Model	Description
SFGR-D127G	5" Service Access Grommet w/o Box
SFGR-D127G/S	5" Service Access Grommet c/w 1 Gang 13A Switched Socket Outlet
SFGR-D127G/R	5" Service Access Grommet c/w 2 nos. RJ45 / RJ11 Knock out Hole

FLOOR PEDESTAL BOXES

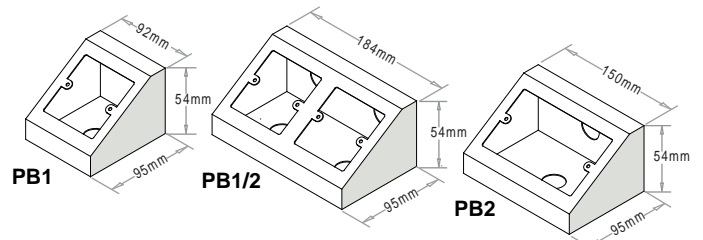

DAVIS Pedestal Boxes are available in 3 designs : 1 gang, 2 x 1 gang and 2 gang for mounting onto Underfloor or Flushfloor Trunkings. They are constructed from pre-galvanized steel sheets with epoxy finish. The socket outlet fixing are in accordance with BS 4662.

OUTLET PANELS

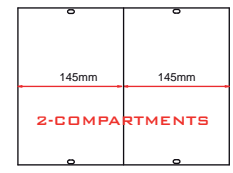
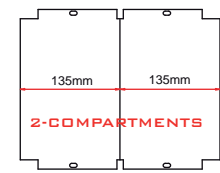
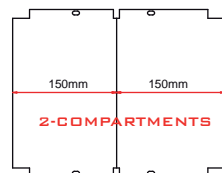
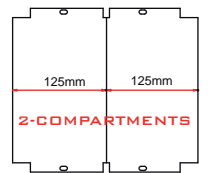
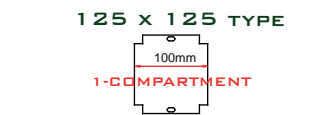
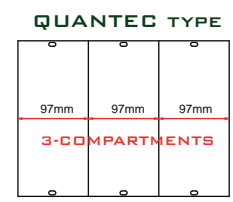
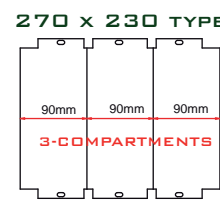
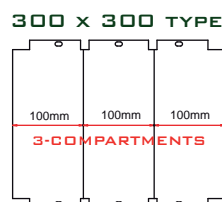
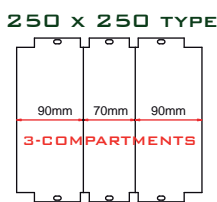
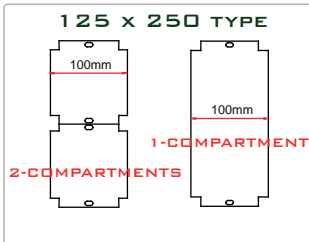
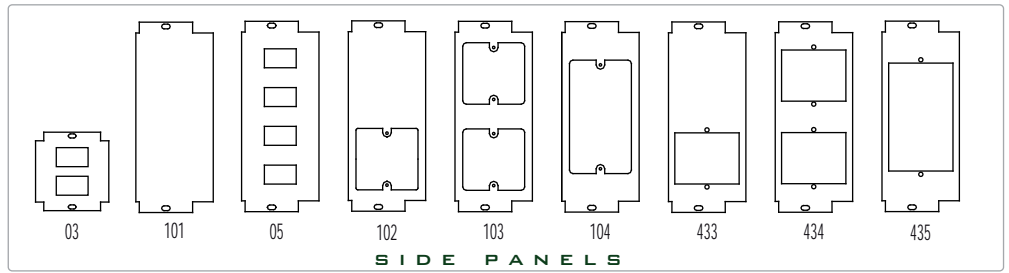
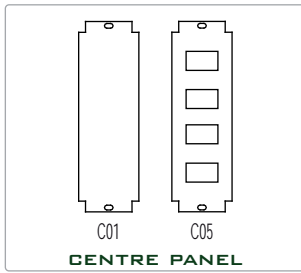

Description	125 x 125		125 x 250		250 x 250		QUANTEC		
	1-Comp.	1-Comp.	2-Comp.	2-Comp.	3-Comp.		2-Comp.	3-Comp.	4-Comp.
					CENTRE	SIDES			
Blank plate				OP125 101	OP70 C01	OP90 101	ST145 C01	ST97 C01	SF72 C01
2 nos. Cut-out RJ45 37x22.5mm	OP125 03S		OP125 03D						
4 nos. Cut-out RJ45 37x22.5mm		OP100 05D		OP125 05	OP70 C05	OP90 05	ST145 C05	ST97 C05	SF72 C05
Cut-out in accordance to BS4662 1G	OP125 102S	OP100 102D	OP125 102D	OP125 102		OP90 102	ST145 102	ST97 102	
Cut-out in accordance to BS4662 2x1G		OP100 103D		OP125 103		OP90 103	ST145 103	ST97 103	
Cut-out in accordance to BS4662 2G		OP100 104D		OP125 104		OP90 104	ST145 104	ST97 104	
1G 13A DAVIS Switched Socket Outlet	OP125 433S	OP100 433D	OP125 433D	OP125 433		OP90 433	ST145 433	ST97 433	
2x1G 13A DAVIS Switched Socket Outlet		OP100 434D		OP125 434		OP90 434	ST145 434	ST97 434	
2G 13A DAVIS Switched Socket Outlet		OP100 435D		OP125 435		OP90 435	ST145 435	ST97 435	

Description	300 x 300			270 x 230		
	2-Comp.	3-Comp.		2-Comp.	3-Comp.	
		CENTRE	SIDES		CENTRE	SIDES
Blank plate	OP150 101	OP100 C01	OP100 101	OP135 2 101	OP90 2 101	OP90 2 101
4 nos. Cut-out RJ45 37x22.5mm	OP150 05	OP100 C05	OP100 05	OP135 2 05	OP90 2 05	OP90 2 05
Cut-out in accordance to BS4662 1G	OP150 102	OP100 C102	OP100 102	OP135 2 102	OP90 2 102	OP90 2 102
Cut-out in accordance to BS4662 2x1G	OP150 103	OP100 C103	OP100 103	OP135 2 103	OP90 2 103	OP90 2 103
Cut-out in accordance to BS4662 2G	OP150 104	OP100 C104	OP100 104	OP135 2 104	OP90 2 104	OP90 2 104
1G 13A DAVIS Switched Socket Outlet	OP150 433	OP100 C433	OP100 433	OP135 2 433	OP90 2 433	OP90 2 433
2x1G 13A DAVIS Switched Socket Outlet	OP150 434	OP100 C434	OP100 434	OP135 2 434	OP90 2 434	OP90 2 434
2G 13A DAVIS Switched Socket Outlet	OP150 435	OP100 C435	OP100 435	OP135 2 435	OP90 2 435	OP90 2 435

Note : All outlet panels supplied are epoxy coated. Non-standard outlet panels are also available upon request.

13A SWITCHED SOCKET OUTLETS - SIDE WIRE ENTRY

DAVIS one and two gang 13A Switched Socket Outlets are specially designed to be slim (24mm) with side wire entries to suit underfloor service boxes.

Rating / Standard : 240V, 13A a.c / BS 1363 : Part 2

3 terminals to : 4x2.5mm² cables each or 3x4.0mm² cables each accommodate

Approved by : JKR & Suruhanjaya Tenaga

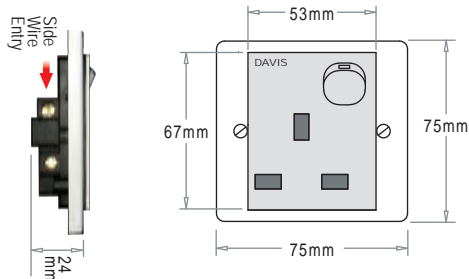

Model	Description
D13/1GS	1 Gang 13A Switched Socket

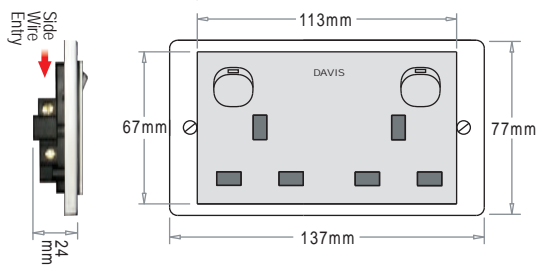

Model	Description
D13/2GS	2 Gang 13A Switched Socket

DATA & TELEPHONE OUTLETS

DAVIS modular type RJ45 & RJ11 data outlets are specially designed to suit underfloor service boxes.

Comply with : TIA/EIA-568-B specifications

Come with : IDC connector and shutter

Hole cut-out : 37mm x 22.5mm

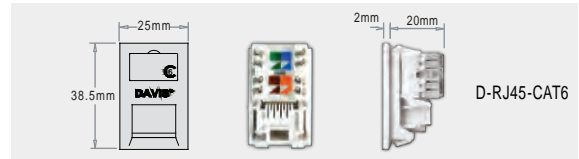

Model	Description
D-RJ45-CAT6	CAT 6 RJ45 Data Outlet - TIA/EIA-568-B